

General Description

WT5522F is a high performance offline PSR controller for low power AC/DC charger and adapter applications. It operates in primary-side sensing and regulation. Consequently, opto-coupler and TL431 could be eliminated. Proprietary Constant Voltage (CV) and Constant Current (CC) control is integrated as shown in the figure 1 below. In CC control, the current and output power setting can be adjusted externally by the sense resistor R_s at CS pin. In CV control, PFM operations are utilized to achieve high performance and high efficiency. In addition, good load regulation is achieved by the built-in cable drop compensation. The chip consumes very low operation current (typical $300\mu\text{A}$), it can achieve less than 50mW standby power to meet strict standby power standard.

WT5522F offers comprehensive protection coverage with auto-recovery features including Cycle-by-Cycle current limiting, VDDH over voltage protection, feedback loop open protection, short circuit protection, built-in leading edge blanking, VDDH under voltage lockout (UVLO), etc.

Typical Application

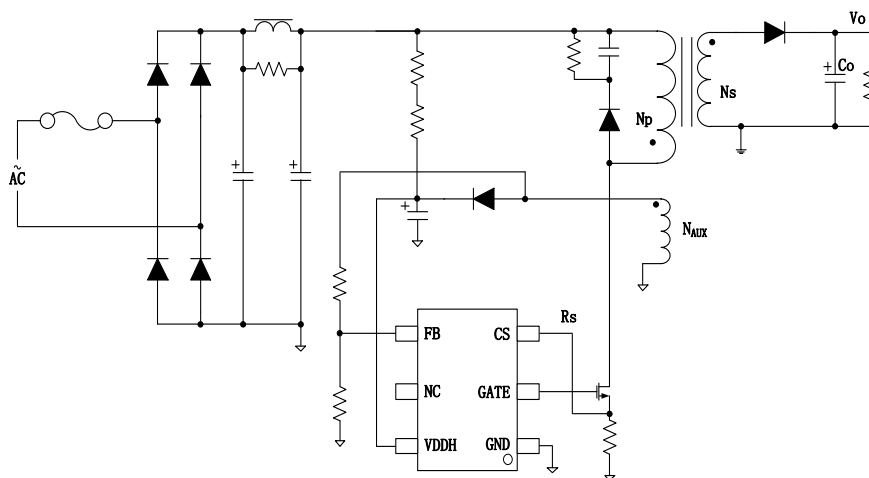

Figure 2. Typical Application Circuit

Features

- $\pm 5\%$ Constant Voltage Regulation at Universal AC input
- High precision Constant Current Regulation at Universal AC input
- Primary-side Sensing and Regulation Without TL431 and Opto-coupler
- Programmable CV and CC Regulation
- Built-in Primary winding inductance compensation
- Programmable Cable Drop Compensation
- Driver MOS Switch
- Ultra Low Start-up Current (Typ. $1\mu\text{A}$)
- VDDH Over Voltage Protection
- Built-in Feedback Loop Open Protection
- Built-in Short Circuit Protection
- Built-in Leading Edge Blanking (LEB)
- Cycle-by-Cycle Current Limiting
- VDDH Under Voltage Lockout with Hysteresis (UVLO)

Applications

- Cell Phone Charger
- Digital Cameras Charger
- Small Power Adapter
- Auxiliary Power for PC, TV etc.
- Linear Regulator/RCC Replacement

Marking information

SOT23-6 (TOP VIEW)

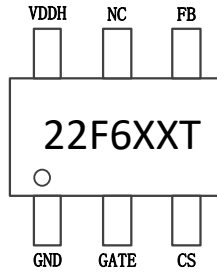

XX: Week Code (01-52)

Terminal Assignments

Pin number	Pin name	Description
1	GND	GND
2	GATE	Gate driver output to drive the external MOSFET
3	CS	Current sense input
4	FB	The voltage feedback from auxiliary winding, Connected to resistor divider from auxiliary winding reflecting output voltage
5	NC	NC
6	VDDH	Power Supply

Absolute Maximum Ratings

Parameter	Value
VDDH Voltage	-0.3V to 30V
CS Input Voltage	-0.3 to 6V
FB Input Voltage	-0.3 to 6V
Min/Max Operating Junction Temperature T _J	-20 to 150°C
Min/Max Storage Temperature T _{stg}	-55 to 150°C
Lead Temperature(Soldering,10secs)	260°C

Note: Stresses beyond those listed under “absolute maximum ratings” may cause permanent damage to the device. These are stress ratings only, functional operation of the device at these or any other conditions beyond those indicated under “recommended operating conditions” is not implied. Exposure to absolute maximum-rated conditions for extended periods may affect device reliability.

Electrical Characteristics

($T_A = 25^\circ\text{C}$, $V_{DDH} = 16\text{V}$, if not otherwise noted)

SYMBOL	PARAMETER	TEST CONDITIONS	MIN	TYP	MAX	UNIT
Supply Voltage (VDDH) Section						
I start-up	Start up current	VDDH=20V		3	5	μA
I static	Static current	VDDH=20V		300	400	μA
UVLO(OFF)	VDDH under voltage lockout exit		18	19	20	V
UVLO(ON)	VDDH under voltage lockout enter		7	8	9	V
VDDH_OVP	VDDH over voltage protection		26	27	28	V
Current Sense Input Section						
TLEB	LEB time			0.5		μS
Vth_ocp	Over current threshold		480	500	520	mV
Td_oc	OCP propagation delay	From OCP comparator to base drive		100		nS
CS Input Section						
Vref_CS	Reference voltage for feedback threshold		2.47	2.5	2.53	V
Tpause_min				2.0		μS
Icomp_cable	Maximum cable compensation current			50		μA

Block Diagram

Figure 3. WT5522F Block Diagram

Operation Description

WT5522F is a cost effective PSR controller optimized for off-line low power AC-DC applications including battery chargers, it operates in primary side sensing and regulation, thus opto-coupler and TL431 are not required. Proprietary built-in CV and CC control can achieve high precision CC/CV control meeting most charger application requirements.

Startup current and Start up control

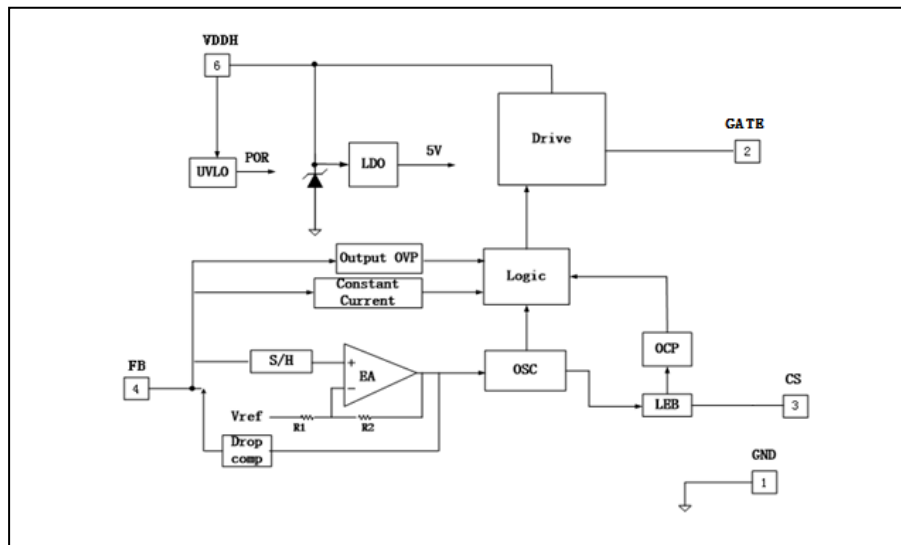
Startup current of WT5522F is designed to be very low so that VDDH could be charged up above UVLO threshold and starts up quickly. A large value startup resistor can therefore be used to minimize the power loss in application.

Operating Current

The Operating current of WT5522F is as low as 300μA. Good efficiency and very low standby power(less than 50mW) is achieved with the low operating current.

CC/CV Operation

WT5522F is designed to produce good CC/CV control characteristic as shown in the Figure 1. In charger applications, a discharged battery charging starts in the CC portion of the curve until it is nearly full charged and smoothly switches to operate in CV portion of the curve. The CC portion

provides output current limiting. In CV operation, the output voltage is regulated through the primary side control. In CC operation mode, WT5522F will regulate the output current constant regardless of the output voltage drop.

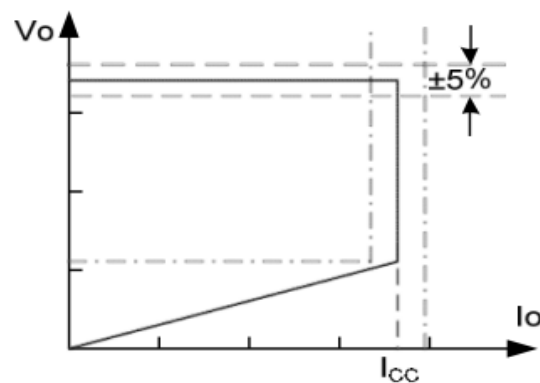

Figure 1. Typical CC/CV Curve

Principle of Operation

To support WT5522F proprietary CC/CV control, system needs to be designed in DCM mode for fly-back system(Refer to Typical Application Circuit).

In the DCM fly-back converter, the output voltage can be sensed via the auxiliary winding. During MOS turn-on time, the load current is supplied from the output filter capacitor, Count. The current in the primary winding ramps up. When MOS turns off, the energy stored in the primary winding is transferred to the secondary side such that the current in the secondary winding is

$$I_s = \frac{N_p}{N_s} \times I_p \quad (1)$$

The auxiliary voltage reflects the output voltage as shown in Figure.2 and it is given by

$$V_{AUX} = \frac{N_{AUX}}{N_S} \times (V_O + \Delta V) \quad (2)$$

Where ΔV indicates the drop voltage of the output Diode.

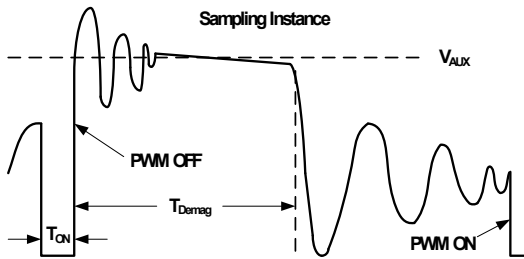

Figure 4. Auxiliary voltage waveform

Via a resistor divider connected between the auxiliary winding and CS (pin 2), the auxiliary voltage is sampled at the middle of the demagnetization and it is hold until the next sampling. The sampled voltage is compared with Vref (2.0V) and the error is amplified. The error amplifier output reflects the load condition and controls the switching off time to regulate the output voltage, thus constant output voltage can be achieved. When the sampled voltage is below Vref and the error amplifier output reaches its minimum, the switching frequency is controlled by the sampled voltage to regulate the output current, thus the constant output current can be achieved.

Adjustable CC point and Output Power

In WT5522F, the CC point and maximum output power can be externally adjusted by

external current sense resistor Rs at ISEN pin as illustrated in typical application diagram. The larger Rs, the smaller CC point is, and the smaller output power becomes, and vice versa as shown in Figure.3.

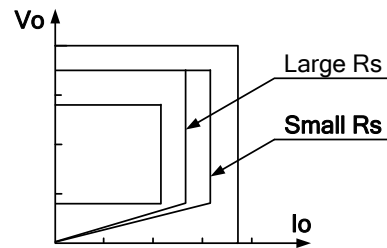

Figure 5. Adjustable output power by changing Rs

Operation switching frequency

The switching frequency of WT5522F is adaptively controlled according to the load conditions and the operation modes. For fly-back operating in DCM, The maximum output power is given by

$$P_{MAX} = \frac{1}{2} \times L_P \times F_{SW} \times I_P^2 \quad (3)$$

Where LP indicate the inductance of primary winding and IP is the peak current of primary winding.

Refer to the equation 3,the change of the primary winding inductance results in the change of the maximum output power and the constant output current in CC mode. To compensate the change from variations of primary winding inductance, the switching frequency is locked by an internal loop such that the switching frequency is

$$F_{SW} = \frac{1}{2T_{Demag}} \quad (4)$$

Since T_{Demag} is inversely proportional to the inductance, as a result, the product LP and FSW is constant, thus the maximum output power and constant current in CC mode will not change as primary winding inductance changes.

Up to $\pm 10\%$ variation of the primary winding inductance can be compensated.

Programmable Cable drop Compensation

In WT5522F, cable drop compensation is implemented to achieve good load regulation. An offset voltage is generated at CS pin by an internal current flowing into the resistor divider. The current is proportional to the switching off time, as a result, it is inversely proportional to the output load current, thus the drop due to the cable loss can be compensated. As the load current decreases from full-load to no-load, the offset voltage at CS will increase. It can also be programmed by adjusting the resistance of the divider to compensate the drop for various cable lines used.

The percentage of maximum compensation is

$$\frac{\Delta V}{V_{out}} = \frac{I_{comp_cable} * (R1 // R2) * 10^{-6}}{2} * 100\%$$

ΔV is load compensation voltage and V_{out} is the output voltage.

For example: $R1 // R2 = 3k\Omega$, the percentage of maximum compensation is

$$\frac{\Delta V}{V_{out}} = \frac{45 * 3000 * 10^{-6}}{2} * 100\% = 6.75\%$$

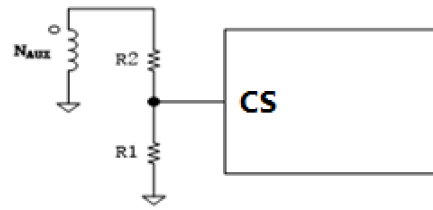

Figure 6.

Current Sensing and Leading Edge Blanking

Cycle-by-Cycle current limiting is offered in WT5522F. The switch current is detected by a sense resistor into the ISEN pin. An internal leading edge blanking circuit chops off the sensed voltage spike at initial power MOS on state so that the external RC filtering on sense input is no longer needed.

Gate Drive

The internal power MOSFET in WT5522F is driven by a dedicated gate driver for power switch control. Too weak the gate drive strength results in higher conduction and switch loss of MOSFET while too strong gate drive compromises EMI.

A good trade-off is achieved through the built-in totem pole gate design with right output strength control.

Protection Control

Good power supply system reliability is achieved with its rich protection features including Cycle-by-Cycle current limiting(OCP), VDDH over Voltage protection, feedback loop open protection, short circuit protection and Under Voltage Lockout on VDDH(UVLO).VDDH is supplied by transformer auxiliary winding output. The output of WT5522F is shutdown when

VDDH drops below UVLO(ON) and the power converter enters power on start-up sequence thereafter.

SOT23-6 PACKAGE OUTLINE DIMENSIONS

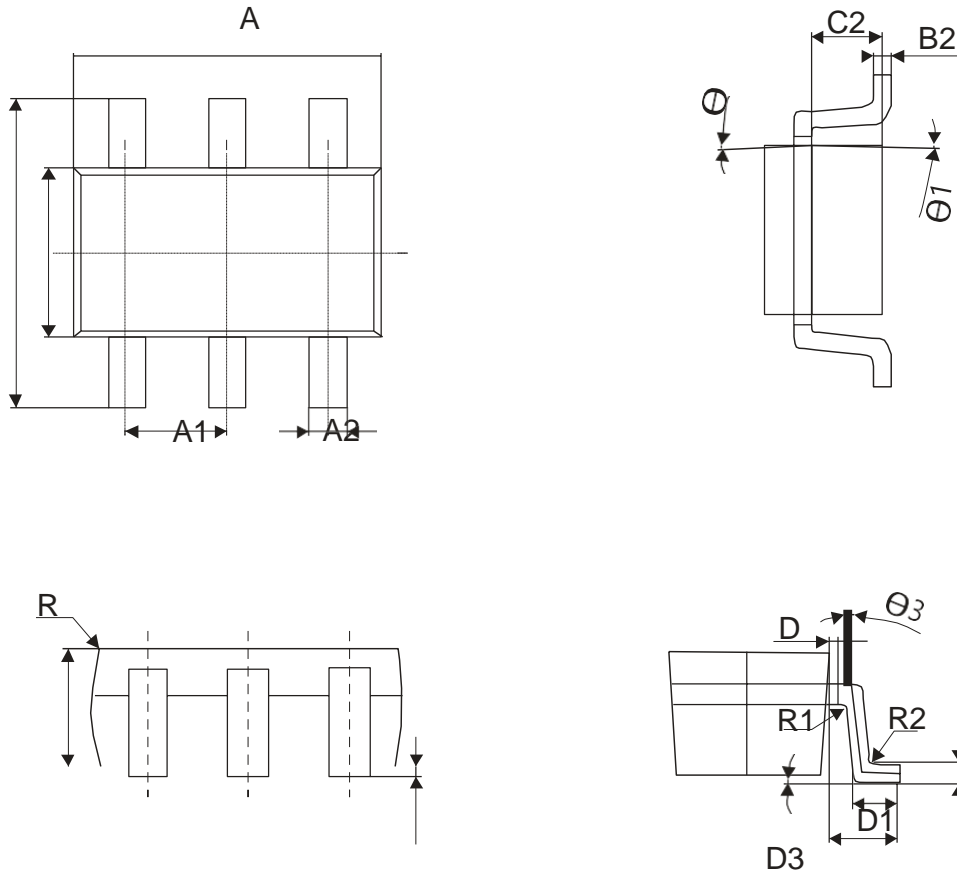

Symbol	Dimensions in Millimeters		Dimensions in Inches	
	Min	Max	Min	Max
A	2.692	3.099	0.106	0.122
B	1.397	1.803	0.055	0.071
C	-----	1.450	-----	0.058
A1	0.838	1.041	0.033	0.041
A2	0.300	0.500	0.012	0.022
B1	2.600	3.000	0.102	0.118
B2	0.119	0.135	0.005	0.005
C1	0.050	0.150	0.002	0.006
C2	0.550	0.750	0.022	0.030
D	0.030	0.130	0.001	0.005
D1	0.300	0.600	0.012	0.024
D2	0.080	0.254	0.003	0.010
D3	0.600	0.700	0.024	0.028