Secondary Feedback PWM Power Switch

Product Description

WT8363B is a high performance and low cost current mode PWM controller which provides several special enhancements designed to meet low standby power requirements. The start-up current is very low, typically 5 μ A, and the operation current is also low. The “No Audio Noise Green Mode” function is integrated to improve the efficiency at light or no load conditions. This green-mode function enables the power supply to meet even the strictest power conservation requirements easily.

The built-in slope compensation ensures the stability of peak current mode control. The integrated frequency jitter function helps to reduce EMI emission of a power supply with minimum line filters.

WT8363B also offers rich protection features including Cycle-by-Cycle peak current limiting, UVLO, VDD over voltage, load OVP, OLP, and OTP.

Pin Configuration

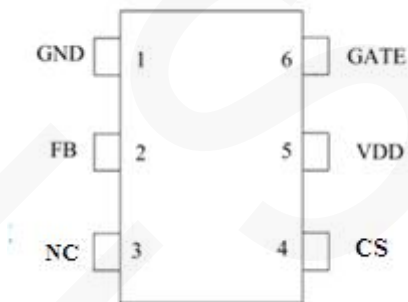

WT8363B

Key Features

- Very Low Start-up Current and Operating Current
- No Audio Noise Green Mode PWM Control
- Frequency Jitter Function to Improve EMI Performance
- Built-in Slope Compensation
- Leading Edge Blanking on CS Pin
- Cycle-by-Cycle peak current limiting
- VDD OVP and Under-voltage Lockout
- OLP (Over Load Protection)
- OUT OVP
- OTP
- Built-in Soft Start
- Drive voltage clamp

Applications

- AC/DC power supply applications
- Power Adaptor
 - Battery Charger
 - PC 5V Standby Power
 - Set Top Box Power Supply



1 Overview

WT8363B is a high performance and low cost current mode PWM controller which provides several special enhancements designed to meet low standby power requirements. The start-up current is very low, typically 5 μ A, and the operation current is also low. The “No Audio Noise Green Mode” function is integrated to improve the efficiency at light or no load conditions. This green-mode function enables the power supply to meet even the strictest power conservation requirements easily.

The built-in slope compensation ensures the stability of peak current mode control. The integrated frequency jitter function helps to reduce EMI emission of a power supply with minimum line filters.

WT8363B also offers rich protection features including Cycle-by-Cycle peak current limiting, UVLO, VDD over voltage, load OVP, OLP, and OTP.

WT8363B is offered in SOT23-6 package.

2 Features

- Very Low Start-up Current and Operating Current
- No Audio Noise Green Mode PWM Control
- Frequency Jitter Function to Improve EMI Performance
- Built-in Slope Compensation
- Leading Edge Blanking on CS Pin
- Programmable Switching Frequency
- Cycle-by-Cycle peak current limiting
- VDD OVP and Under-voltage Lockout
- OLP (Over Load Protection)
- OUT OVP
- OTP
- Built-in Soft Start
- Drive voltage clamp

3 Pin Diagrams

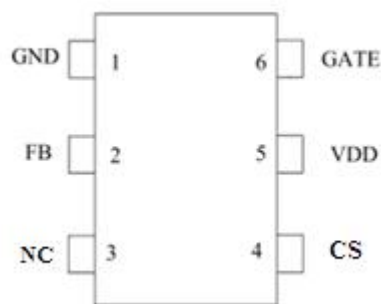

WT8363B

4 Pin Description

Pin	Description
VDD	IC power supply.
NC	Floating pin
FB	Feedback input pin receive the feedback signal from the second side via an opto-coupler and control the CS peak value and operating frequency.
CS	Current sense pin. Connected to an external voltage sense resistor.
GATE	Totem-pole gate drive output for the power MOSFET.
GND	IC ground.

5 Absolute Maximum Ratings

Absolute maximum ratings are the parameter values or ranges which can cause permanent damage and affect device reliability if exceeded.

Parameter	Symbol	Value	Units
DC Supply Voltage Range	VDD	-0.3 to +30	V
CS Input	CS	-0.3 to 7	V
FB Input	FB	-0.3 to 7	V
Maximum Junction Temperature	Tjmax	150	°C
Storage Temperature	Tsto	-55 to 150	°C

Note: These are stress ratings only. Stress beyond these limits may cause permanent damage to the device. Functional operation of the device at these or any conditions beyond those indicated under Recommended Operating Conditions is not implied. Exposure to absolute maximum rated conditions for extended periods of time may affect device reliability.

6 Recommended Operating Conditions

Parameter	Min	Max	Unit
Operating Ambient Temperature	-40	+105	°C

7 Block Diagram

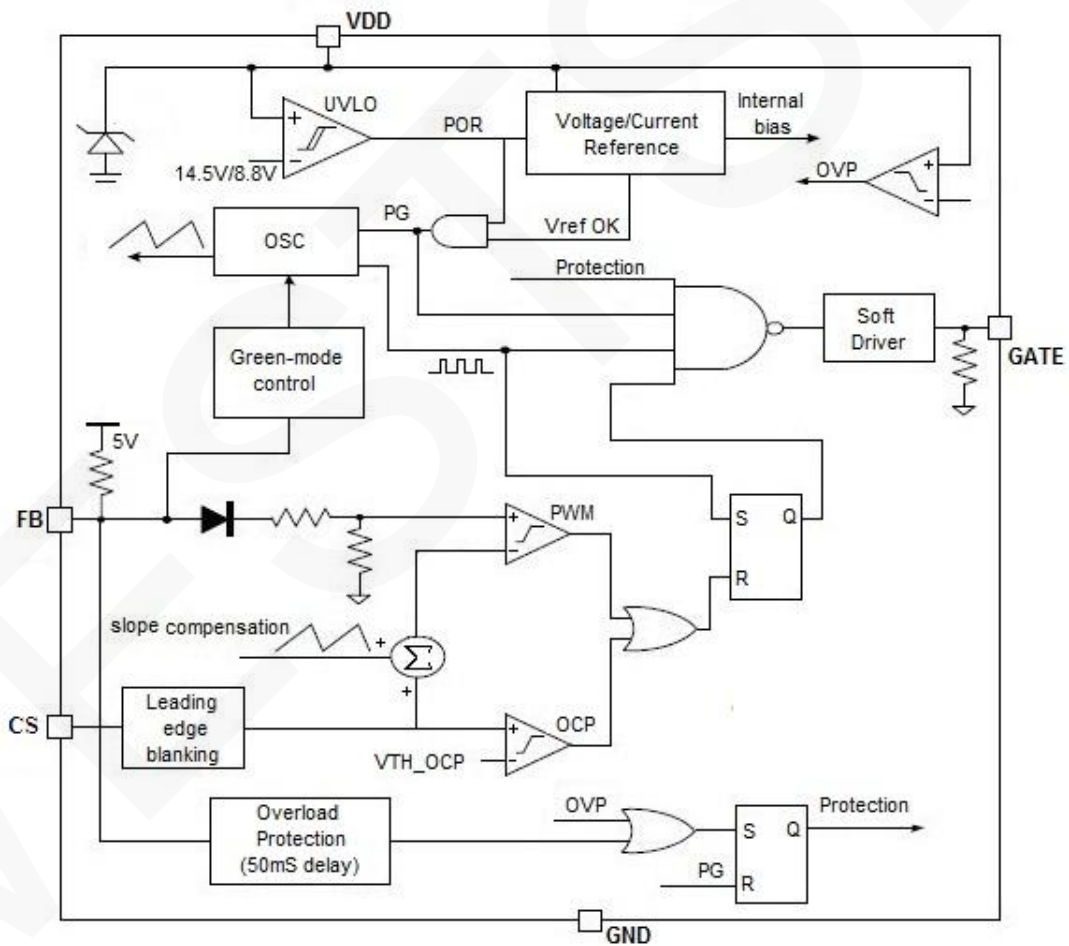

8 Electrical Characteristics

(VDD =16V, TA = 25°C, unless otherwise specified)

Parameter	Symbol	Test Conditions	Min	Typ	Max	Unit
VDD SECTION (VDD)						
VDD Start up Current	IDD_st	VDD=VDD_ON-0.5V		5	20	uA
VDD UVLO Exit	VDD_ON	VDD rise		18		V
VDD UVLO Enter	VDD_OFF	VDD fall		8		V
VDD Over Voltage Protection Level	VDD_OVP	VDD rise		28		
Operating Supply Current	IDD_op	V _{FB} =3V		1.2		mA
FEEDBACK SECTION (FB)						
FB Open Loop Voltage	V _{FB_open}			5		V
FB Pin Short Circuit Current	I _{FB_short}			0.3		mA
Burst Mode FB V _{th}	V _{TH_OD}			1.4		V
Over Load Protection FB Threshold Voltage	V _{TH_PL}			4.3		V
OLP Delay Time				50		ms
CURRENT SENSE SECTION (CS)						
Soft start time	T_soft			4		ms
Leading Edge Blanking Time	T_LEB			300		ns
Propagation Delay Time	Td_ocp			120		ns
Over Current Protection Threshold Voltage	V _{th_OCP}		720	750	780	mV
OSCILLATOR (FOSC)						
Normal PWM Frequency	Fop		50	55	60	KHz
Maximum Duty Cycle	Dmax	V _{FB} =3V, CS=0		75		%
Green-mode Minimum Frequency	F_Burst			22		KHz
Frequency Jitter Range			-4		+4	%
OTP						
Over temperature protection point	TREG			145		°C

9 Application

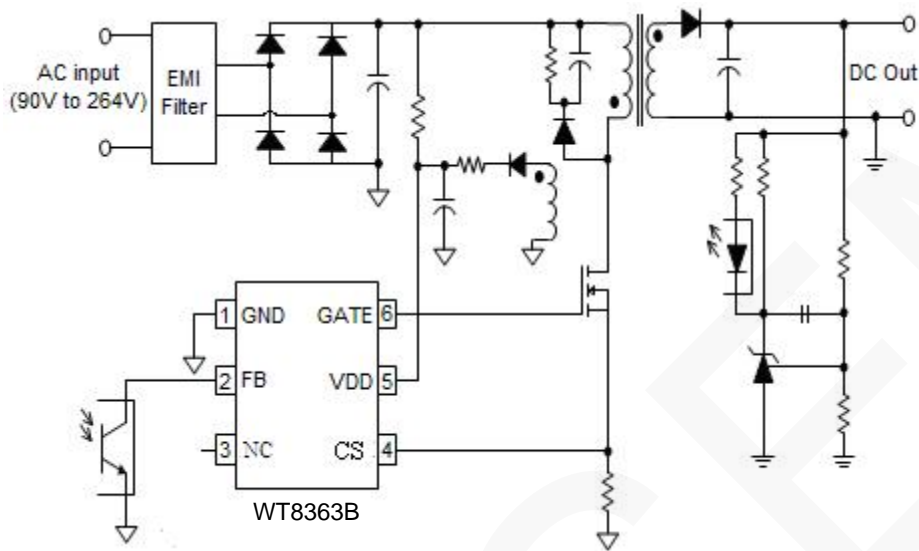

Application Notes

WT8363B includes all necessary function to build an easy and cost effective solution for low power supplies to meet the international power conservation requirements.

9.1 Startup & Operating Current

WT8363B has a very low start-up current typically 5 μ A, and the operation current is also low, typically 1.2mA. In "No Audio Noise Green Mode", the operation current is typically 0.6mA, so we could get high efficiency especially in light load.

9.1 Soft Start

WT8363B features an internal 4ms (typical) soft start to soften the electrical stress occurring in the power supply during startup. It is activated during the power on sequence. As soon as VDD reaches VDD_ON, the peak current is gradually increased from nearly zero to maximum 0.75V. Every restart up is followed by a soft start.

9.3 No Audio Noise Green-mode Operation

At light load or no load condition, the switching loss become the major loss of the power supply.

To power dissipation in light and no load conditions, WT8363B adaptively adjust the switching mode according to the load condition based on the voltage of FB pin. In light load condition, the FB voltage will decrease, when VFB is lower than a set threshold voltage, the power supply enters into green-mode operation and the PWM frequency will continuously be decreased, the minimum frequency is set about 20kHz. When VFB voltage decreases further, the power supply will enter into burst mode operation to decrease the power dissipation at no load condition. Besides, there is no audible noise in any load condition.

9.4 Frequency Jitter

The frequency jitter function is integrated in the controller, the jitter is modulated by a periodic signal, the modulate signal frequency is much smaller than the oscillator frequency, by this way, the EMI noise has a wider spectrum with lower amplitudes.

9.5 Current Sensing and Leading Edge Blanking

The typical current mode of PWM controller feedbacks both current signal and voltage

signal to close the control loop and achieve regulation. The WT8363B detects the primary MOSFET current from the CS pin, which is not only for the peak current mode control but also for the cycle-by-cycle current limit. Each time when the power MOSFET is switched on, a turn-on spike will inevitably occur on the sense-resistor. To avoid premature termination of the switching pulse, a 300nS leading-edge blanking time is built in. Conventional RC filtering can therefore be omitted. During this blanking period, the current-limit comparator is disabled and it cannot switch off the gate driver.

9.6 Built-in Slope Compensation

The sensed voltage across the CS resistor is used for PWM control, and cycle by cycle current limit, Built-in slope compensation circuit adds a voltage ramp onto the current sense input voltage. This greatly improves the close loop stability and prevents the sub-harmonic oscillation of peak current mode PWM control scheme.

9.7 Protection Control

WT8363B has built-in rich protection features including Cycle-by-Cycle Current Limiting, VDD over voltage, Under Voltage Lockout on VDD, Output OVP , OLP and OTP Protection.

10 Packaging Information

SOT23-6 package

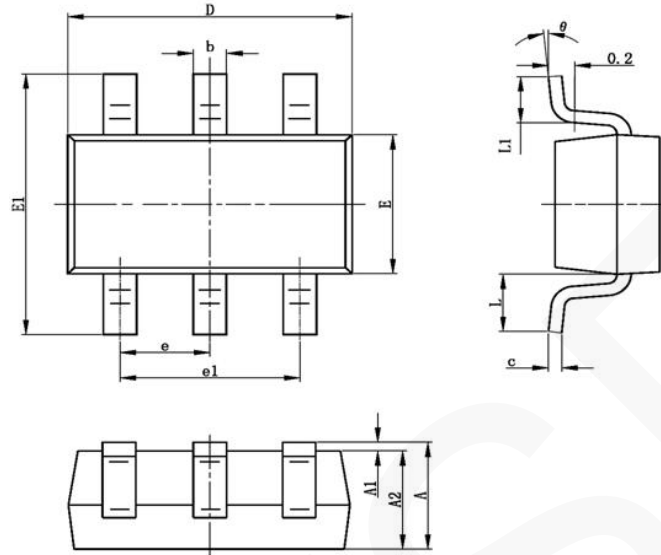

Symbol	mm		Inch	
	Min	Max	Min	Max
A	1.050	1.250	0.041	0.049
A1	0.000	0.100	0.000	0.004
A2	1.050	1.150	0.041	0.045
b	0.300	0.400	0.012	0.016
c	0.100	0.200	0.004	0.008
D	2.820	3.020	0.111	0.119
E	1.500	1.700	0.059	0.067
E1	2.650	2.950	0.104	0.116
e	0.950TYP		0.037TYP	
e1	1.800	2.000	0.071	0.079
L	0.700REF		0.028REF	
L1	0.300	0.600	0.012	0.024
θ	0°	8°	0°	8°